

ADJUSTABLE BORE GAGE SETMASTERS

Bore gages are comparative instruments used to compare parts being manufactured to known dimensions. "Setting" the bore gage to a known dimension requires the use of a reference master. The master ring is the most common type reference master used in the industry and each ring is limited to one specific hole size. This means that a master ring inventory can reflect a large investment. Dorsey's adjustable bore gage setmasters maintain all the advantages of master rings, but provide the added feature of adjustability. Within the specified capacity of each Dorsey "Setmaster", any dimension can be set by easily adjusting the master to a preset combination of gage blocks.

FEATURES:

- ✓ Only five setmasters are required to cover a range between .25" and 36".
- ✓ Mastering cycle repeatability within .000050".
- ✓ Setting cycle repeatability within +/- .00010".
- ✓ Ring correlation accuracy within +/- .00010".
- ✓ Used to set Dorsey DBL or Dorsey/Standard Series bore gages.
- ✓ Can also be used to set many other brands of bore gages - contact us for details.

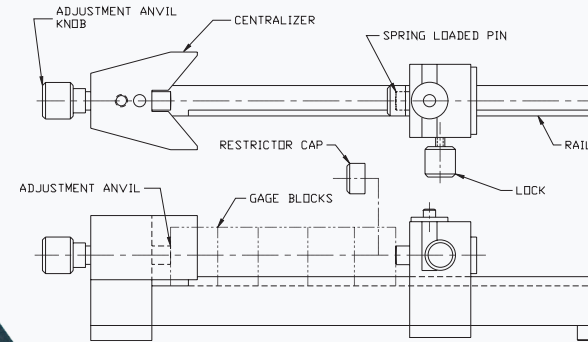

DBM-24000 20"-36"

DBM-12000 12"-24"

DBM-1000 1"-6"

DBM-6000 6"-13"

DBM-250 .25"-1"



*DBL-300
Shown being
set with DBM-
1000 master*

